

Available



For Lease
Avalon Distribution Park
8 Double Dock-Hi Units
5,800 SF to 15,000 SF



14410 S. Avalon Boulevard
Gardena, CA 90248
Unincorporated L.A. County

BUILDING FEATURES:

- 2 or 4 Dock-Hi Positions per Unit
- 24' Minimum Clear Height
- New Construction—Available February 2009
- Designed for Freight and Distribution Companies
- Concrete Yard Area - 115' Truck Court
- 3 bathrooms; Shop Sink; 480 V Power

LOCATION FEATURES:

- Adjacent to Harbor (110) and Century (105) Freeways
- Equidistant between the Harbor, LAX and Downtown L.A.
- Suitable for Air and Ocean Freight

Klein Commercial
Real Estate, Inc.
517 14th Street
Santa Monica, CA 90402
Tel. 310-451-8121
www.kleincom.com

James Klein, SIOR
Klein Commercial
310-451-8121

Roger D. Egge
Private Capital Realty Advisors
949-458-7378



14410 S. Avalon Boulevard Gardena, CA 90248

Unincorporated L.A. County

James Klein, SIOR
Tel. 310-451-8121
www.kleincom.com

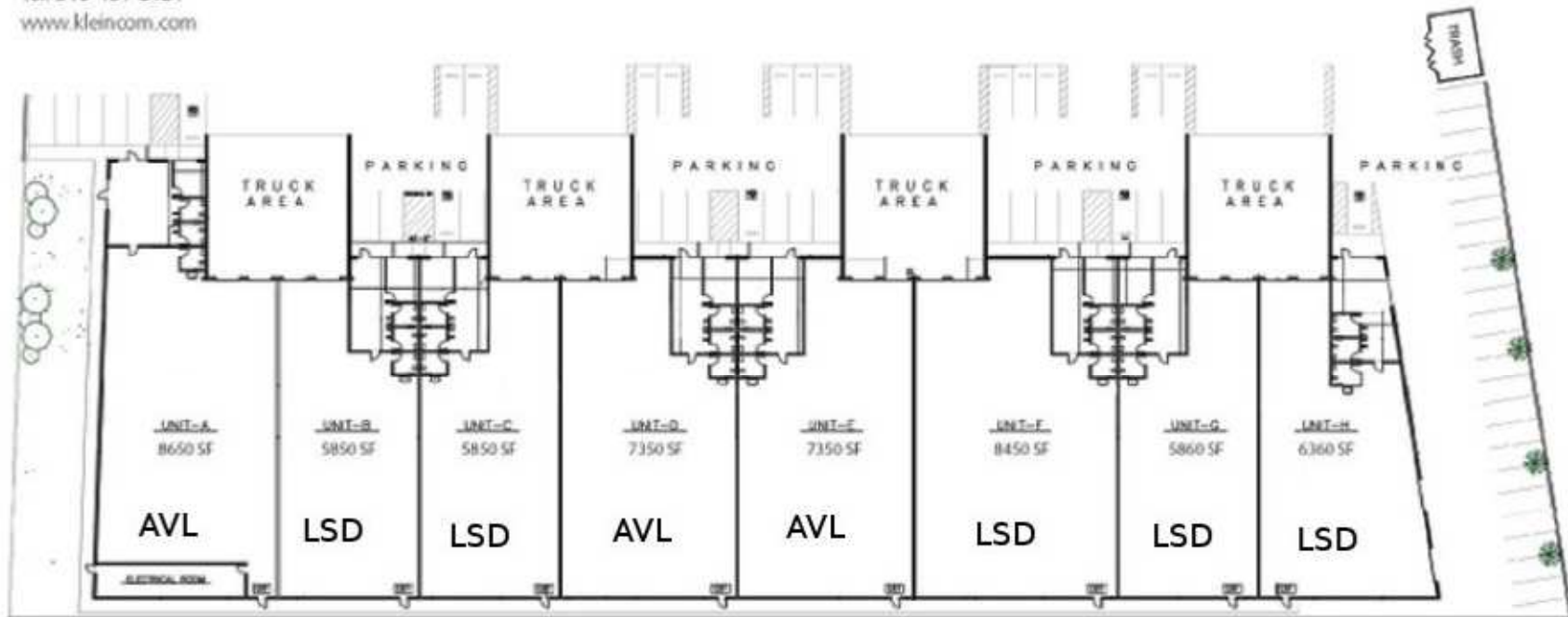

Each unit has:
2 dock-hi positions
750 sf of offices*
3 bathrooms
115' minimum for truck maneuvering

*except unit 'A' - 1,000 sf offices.